

	deutsch	english	français	italiano	español	nederlands
	Karussellschrank	Carousel corner base unit	Élément bas tourniquet	Base con cestelli girevoli	Módulo carrusel	Carrouselkast
	Montageanweisung	Installation instruction	Notice de montage	Istruzione di montaggio	Instrucción de montaje	Montagevoorschrift
	<ul style="list-style-type: none"> <li>- Nicht am Lagerkreuz tragen.</li> <li>- Transportsicherungsschraube entfernen.</li> </ul>	<ul style="list-style-type: none"> <li>- Do not use fixing bracket to carry.</li> <li>- Remove securing screw from upper axle bearing.</li> </ul>	<ul style="list-style-type: none"> <li>- Ne pas employer croix de montage pour porter.</li> <li>- Enlever la vis sécurité pour le transport.</li> </ul>	<ul style="list-style-type: none"> <li>- Non usare la staffa a croce per il trasporto.</li> <li>- Eliminare la vite di sicurezza per il trasporto.</li> </ul>	<ul style="list-style-type: none"> <li>- No emplear las crucetas de montaje para el transporte.</li> <li>- Retirar el tornillo de seguridad para el transporte.</li> </ul>	<ul style="list-style-type: none"> <li>- Niet het lagerkruis gebruiken om te dragen.</li> <li>- Transportveiligheidschroef verwijderen.</li> </ul>

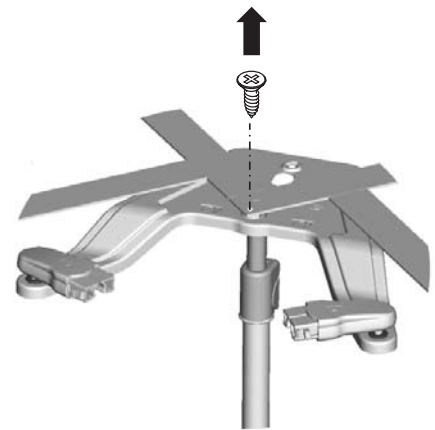
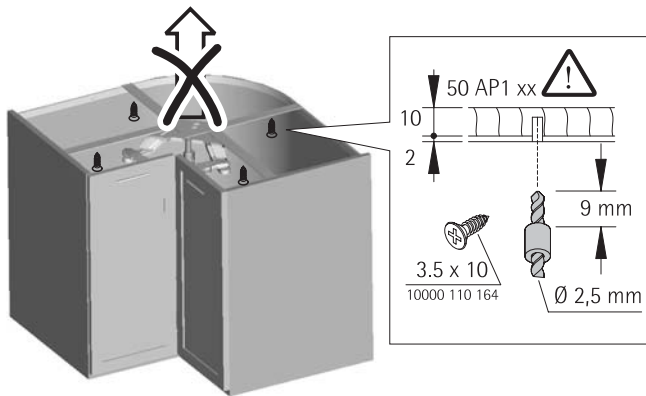

10/07

10000.119 298

Justrieren der Fronten	Adjustment of the doors	Ajuster les portes	Aggiustare gli sportelli	Ajustar el frontal	Front justeren
------------------------	-------------------------	--------------------	--------------------------	--------------------	----------------

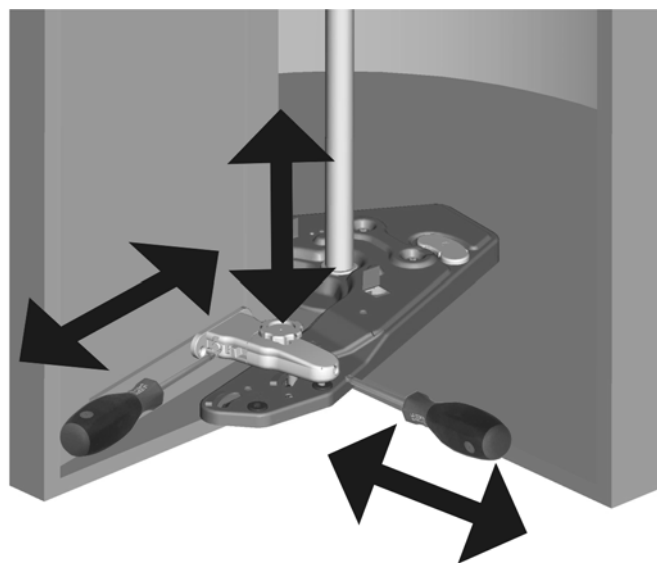

deutsch	english	français	italiano	español	nederlands
Einstellung der Schließgeschwindigkeit	Adjustment of the closing speed.	Réglage de la vitesse de fermeture.	La regolazione della velocità di chiusura.	El ajuste de la velocidad final.	De regeling van de sluiting snelheid.

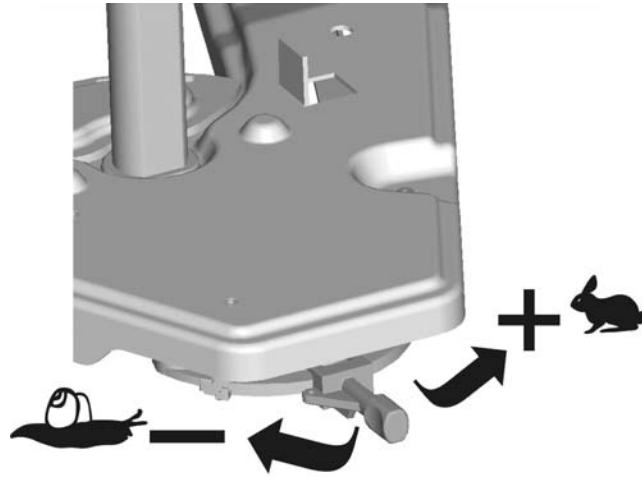

Höheneinstellung der Tablare	Height adjustment of the shelf support.	Réglage de l' hauteur du plateau.	La regolazione di altezza del sostegno di scaffale.	El ajuste de la altura del apoyo de estante.	De hoogte regeling van de plank steun.
------------------------------	---	-----------------------------------	---	--	--

